

BRANCHING OUT



BATS AND WHITE NOSE SYNDROME

INSIDE THIS ISSUE:

<i>Bluebirds</i>	2
<i>Pond Management</i>	2
<i>Apple Trees</i>	3
<i>Alternative Income</i>	3
<i>Habitat for Humanity</i>	4



The Rainforest Alliance works to conserve biodiversity and ensure sustainable livelihoods by transforming land-use practices, business practices, and consumer behavior. FSC® certified by the Rainforest Alliance



The mark of responsible forestry

White-nose syndrome (WNS) is a disease of hibernating bats that has spread from the northeastern to the central United States at an alarming rate. Since the winter of 2007-2008, millions of bats in 25 states and five Canadian provinces have died from this disease.

Current estimates of bat population declines in the northeastern US since the emergence of WNS are approximately 80%. This sudden and widespread mortality associated with WNS is unprecedented in hibernating bats. It is unlikely that species of bats affected by WNS will recover quickly because most are long-lived and have only a single pup per year. Consequently, even in the absence of disease, bat populations do not fluctuate widely in numbers over time.

Bats are very beneficial to humans thanks to their voracious appetite for insects. A typical bat can eat about 1,000 insects per hour. The 20 million bats in the famous Bracken Cave in Texas consume 200 tons of insects each night. Because eating insects means there are fewer of them eating our crops, it is estimated that this is worth some \$22 billion annually to US ag farmers alone.

So what can you do to ensure that you have nature's insect vacuums on your property? Bats need 3 things: roosting areas, foraging space, and water. Bats prefer to roost in the tops of dead trees in summer. Preferably trees with cracks and scaly bark to crawl under. They are sensitive to disturbance, so once you identify bats roosting

in trees, try to avoid the area.

Bats forage for insects mostly within a 1 or 2 mile range of the roosting tree. They prefer somewhat open conditions. Some species prefer a thinned forest, while others need an open field. For water, they prefer to drink "on the wing" (while flying) over an open body, such as a quarter acre pond or larger.

You can always build a bat house to attract bats and help with habitat. Find out more from state extension in your area online.

Portions of this article condensed from, USGS, National Wildlife Health Center, "White-Nose Syndrome", May 2014.



Little brown bat (left), Indiana bat (right). Photo Credit: US Fish and Wildlife

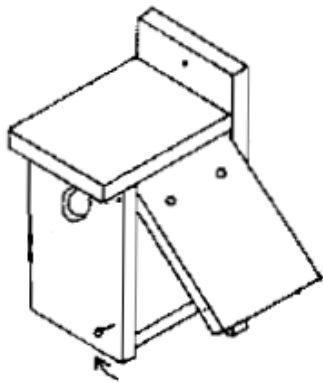

Nail or screw holds side closed

ATTRACTING BLUEBIRDS

Eastern bluebirds are one of the most popular songbirds that people like to attract to their backyards. These birds thrive in areas of mixed hardwood forests and grasslands. Grasslands could be pasture or even backyards. Often, putting a few bluebird houses on your property is all it takes to bring them to your backyard.

Bluebirds are attracted to water features that splash or make noise. Bluebirds will eat dried fruit and sunflower seeds, but they prefer mealworms. Species to plant for bluebirds, or birds in general: dogwood, wild grapes, hackberry, blackberries, service berry, hawthorn, sumac, and blueberry. Basically, soft mast or small fruit producing trees and shrubs.

Below and on the left side of the page is a plan for building a simple bluebird house. The hole on the front should be 1 1/2 inches. Avoid treated lumber or painting the box. Install the boxes in March or April, about 6 feet high and near an open area. Make sure it's in an area that receives some shade during the day.

Happy Birding!

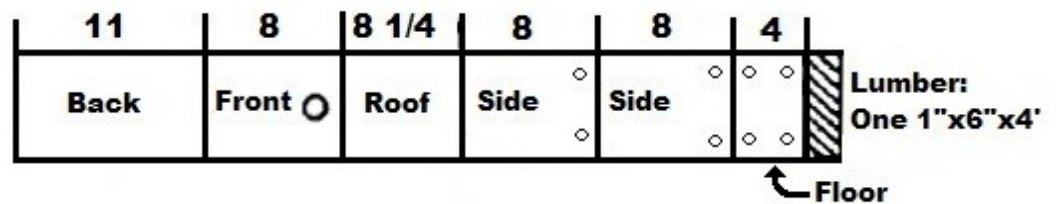

BASIC POND MANAGEMENT

A pond is a great way to increase habitat and wildlife diversity on your property. But did you realize that like a forest, a pond also needs care and management?

Before building a pond, you should contact local extension to make sure you comply with state and federal laws. Also, pond location on your property is critical to its quality, and therefore your enjoyment.

If you have a shaded location, with a cold spring feeding into your pond, you may have the right elements to create a trout pond. For most ponds, particularly those surrounded by open fields, you need to stock it with bass. Stocking rates vary widely depending on the acreage of your pond. One of the most successful stocking combinations is largemouth bass and bluegill. Recommended initial stocking rates of fingerling fish per acre are: 75–100 bass and 500 bluegill. Many people often add channel catfish as well. These should be stocked (with bass and bluegill) at 50–75 per acre.

Just as crops and trees grow better with the right fertilizer and nutrients, ponds also require nutrient management. Fertilizing increases the phytoplankton in the water, which determines the amount of food available for the pond ecosystem. A fertilized pond can produce 2 to 4 times more fish per acre than one left to nature. Of course, this means that fish must be harvested more frequently to balance their populations. That's right; in order to properly manage your fish pond, you have to spend time fishing!

Some ponds may not require fertilizer, and you can reduce fish, or create too much algae and plants with improper use. Also, some ponds are naturally fertile. Lastly, if you are feeding the fish, then fertilizer may not be worthwhile.

Just as unwanted plants and weeds produce problems for forests and gardens, aquatic weeds must be managed in ponds and lakes. This is best managed with proper water depth and shoreline slope. Do not fertilize until you have

aquatic weeds under control. Runoff from agriculture that ends up in your pond or lake can be rich in fertilizer and nutrients and must be considered in your pond management. There are also herbicides and mechanical controls to consider for removing weeds.

You should keep records of the fish that are caught in your pond. This helps determine populations and is useful to determine proper stocking of each species. Sometimes fish kills occur, or you may notice scale diseases or parasites on live fish. Treating this is expensive, so it's best to focus on prevention. This means balancing fish populations, maintaining water quality, and managing pond vegetation.

There are more tools and recommendations and management guidelines in the publication: "Managing Small Fishing Ponds and Lakes in Tennessee", TWRA, March 2009.



APPLE TREES

Planting fruit trees on your farm or around your forest provides food for wildlife and for the tree farmer as well. Depending on your location, you may consider peach, pecan, cherry, pear, plum, the list is probably endless. But for most climates and elevations, there is some variety of apple tree that you can grow successfully.

Local extension can help determine what varieties you can grow successfully. You should plant several trees of different varieties to ensure cross pollination and therefore plenty of apples. Apple trees grow best in well-

drained, fertile soils. They prefer slightly acidic soils and they need full sunlight. They should be planted 10 to 20 feet apart, depending on variety and rootstock (if using commercial rootstock).

The best planting time is late fall and early winter. Control vegetation with mulch around the tree. Take a soil sample before planting to determine the soil nutrient characteristics. After trees mature (several years), you can estimate the need for fertilizer based on branch growth. Less than 10 inches in a year may indicate the need to fertilize.

Apple trees need to be pruned regularly to maintain vigor and aid in producing full crops of apples. Pruning should be done in late fall or early winter when the tree is dormant.

Insects and disease often can be addressed with organic methods, but you may occasionally need an insecticide. At the first sign of leaf or fruit damage, contact local extension for assistance.

Trees will produce fruit within 5 or 6 years. Enjoy!



GENERATING REVENUE FROM YOUR FOREST

In the last newsletter, we talked about non-timber forest products, such as herbs or firewood, that can earn money for landowners in between timber harvests. This article explores additional ways to create alternative income from your forestland and related resources. Bear in mind that some of these ideas may require additional insurance or legal compliance consideration in your state. Also, combining some of these activities will strengthen your ability to generate revenue from them.

Bed and Breakfast—if you have the right house, or even a barn that can be converted into a living space, you can start a bed and breakfast business. Trails for hiking, or if your farm is centrally located to regional attractions, can make this a successful enterprise.

Tourist Farm—if you have a working agriculture farm on

your property, people are willing to pay money to live in the past. Popular activities include: milking cows, churning butter, caring for farm animals, hayrides and the like. Livestock, such as cows and goats, and other animals, such as ducks and rabbits, are an important component of a tourist farm.

Recreational activities—your forestland, depending on its features, may be conducive to: hunting and fishing leases, bird watching, cross country skiing, hiking, or even sporting clays. Fees for use, such as day passes, can generate revenue from this activity. Camping is a popular activity, particularly if you can provide a wilderness experience only a few yards away from the parking lot. Also, if you have access to a popular river or trail, you may be able to make money from parking fees.

Fish pond—(see article about ponds on page 2) If you have a pond or small lake on your forestland, you may have opportunities for recreation and aquaculture. Aquaculture is growing fish for food, bait, or just maintaining a fish pond and charging fees.

Paintball—A few acres of forest, and some well placed plywood structures are all that's needed to convert a section of your forest to a competitive paintball arena.

You may need to build infrastructure such as: parking lots, boardwalks, or even additional buildings or shelters. Plan carefully and make sure these activities fit in with your long-term management goals.

Condensed from "Alternative Income Enterprises—Resource List", Maryland Cooperative Extension, Jonathan S. Kays

Your forestland could be the centerpiece of a bed and breakfast, or even a wilderness campground

**Corporate
Headquarters**

7900 Triad Center Dr
Greensboro, NC 27409
800-637-1609

Timber Offices

Old Fort, NC
Greg Decker
828-724-9495

Craigsville, WV
Chris Neal
304-742-5317

Klamath Falls, OR
Mark Slezak
541-273-2504

Newport, VT Veneer Division
Dwight Jensen
802-334-6711

Forest Certification Manager
Richard Taylor Jr
423-914-3446

Appalachian Timber
Manager
Jim Sitts
888-737-0514

HABITAT FOR HUMANITY

In 2014, Columbia partnered with Habitat for Humanity locally in Greensboro, NC. Columbia has partnered with Habitat before in supplying building materials and volunteer labor. This year, however is the first year that Columbia has sponsored an entire home.

Columbia and its employ-

ees regularly look for opportunities to serve their communities. Most of our plywood mills donate materials to schools and community projects. The partnership with Habitat continues the philosophy of giving that is part of the culture of Columbia's employees.

Cabinets for Humanity is a partnership program in which Columbia donates the

lumber and prefabricates the cabinet parts at their mill. Habitat Greensboro then sells the cabinet components to other Habitat programs and consumers. A portion of sales from Cabinets for Humanity supports the State Habitat organization. Cabinets kits will also be supplied to projects in Virginia, Alabama, and Florida this year.

**FIND OUR PLYWOOD IN PROJECT PANEL
SIZES AT THE HOME DEPOT**

For DIY woodworkers and remodelers, shelving, cabinetry and furniture projects have gotten much easier and more convenient now that Columbia has teamed up with The Home Depot to offer top-quality, American hardwood plywood project panels through an exclusive online program. The panels are now available in a choice of 12 different unfinished, prefinished and primed hardwood veneer faces, including Maple, and are available as "ship to home" or "ship to store" items from The Home Depot website.

Responding to the need for better convenience and easier handling, PureBond Project Panels are offered in a choice of smaller sizes:

- 2' x 2' 2' x 4'
- 2' x 8' 4' x 4'

WE'RE ON THE WEB!

You can visit our site at: www.columbiaforestproducts.com. Please come by on occasion and look for our forestry section for landowners. (Click on "Library" then select from the "Forestry" section)